

DB Flex Corner Section

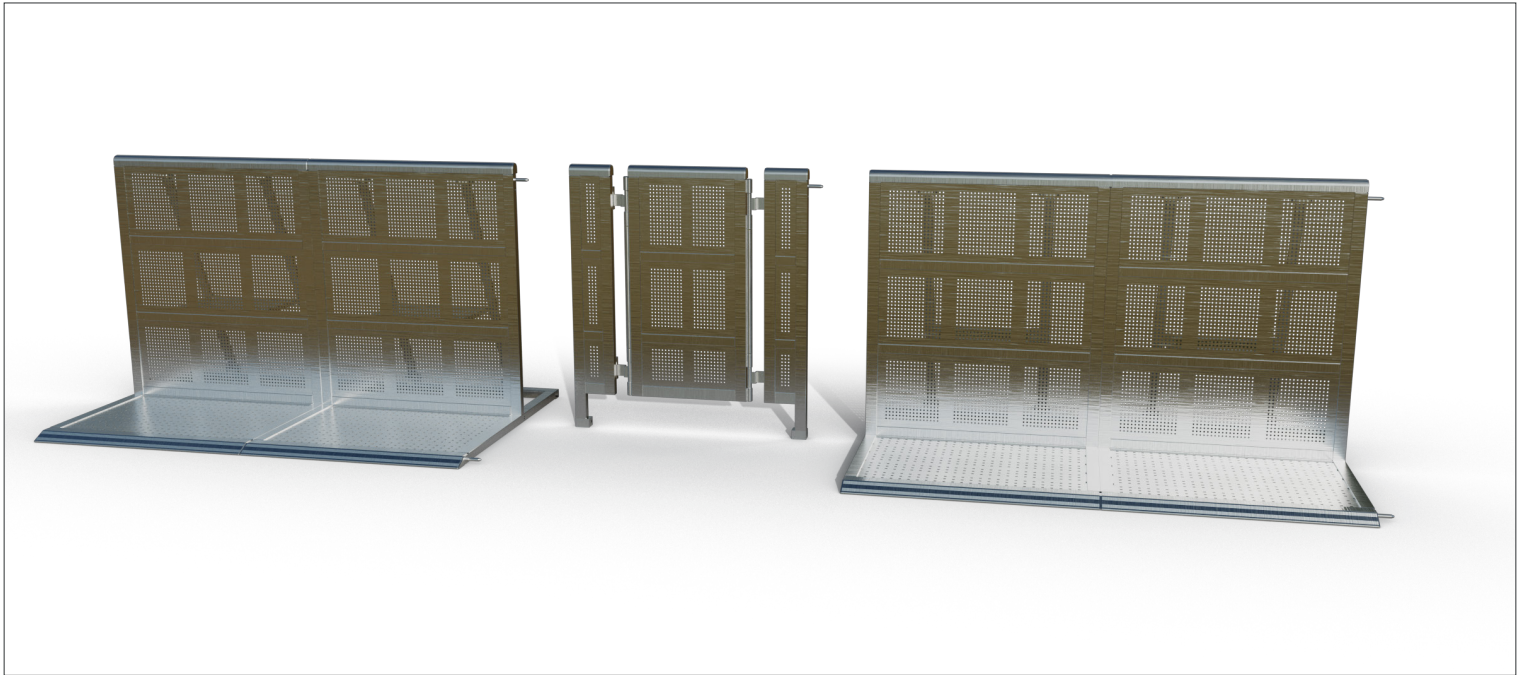

Dutch Barrier's flex corner section provides a solid yet flexible corner crowd control solution. It should be installed between straight sections only. Although it withstood the same 5kN/m test condition, we recommend only using it in reduced maximum crowd pressure areas due to the lack of braces and treadplate a.o. They are stored and travel per 15 in an all-new handling-friendly dolly system.

- a state of the art aluminium barrier system, built for fast setup and optimised crowd control solutions -

About

Dutch Barrier's founders and partners boast over 50 years of experience in high-end manufacturing, layout design, and crowd control solutions. We saw an opportunity to start afresh with an entirely new stage barrier design, preserving the best features and improving upon them where possible.

Why

We believe in quality, safety, and creating an unforgettable experience. The safer an audience is, the more comfortable it will feel at your event.

How

We achieve quality and safety by leveraging 50-plus years of combined original creators' experience to reinvent the to date world's best barrier system from the ground up, making it accessible to anyone who might be in the market for such a system, either to rent or to buy.

What

Dutch Barrier® is a state-of-the-art lightweight aluminium barrier system offering an innovative combination of straights, special sections and storage solutions. Create ingenious crowd control solutions, enjoy quick setups and enhanced handling, and benefit from an equal footprint for every dolly during transport or storage.

Oh, and there's one more thing...

Dutch Barrier® is not just a brand. It's a state-of-the-art engineering company where customer support is an integral part of the mission rather than being hidden behind the impersonality of an online promise.

More information: info@dutchbarrier.nl

Rental & Sales: info@dutchbarrier.services

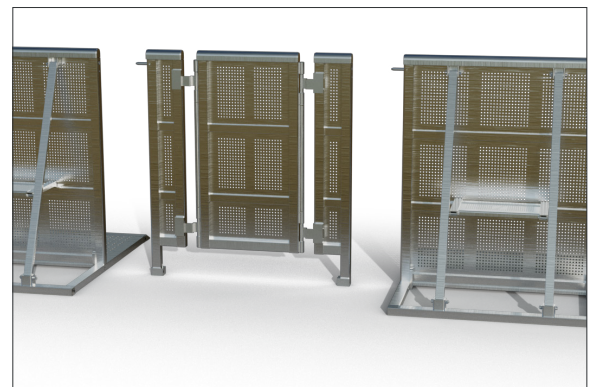
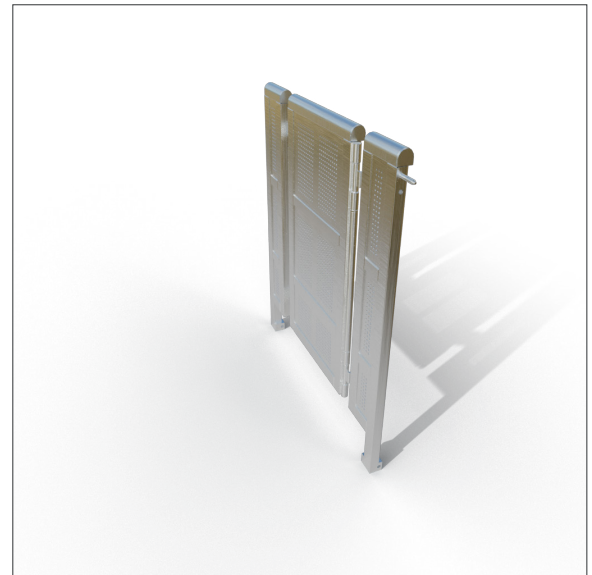

- a safe show for every row -

DB Flex Corner Section

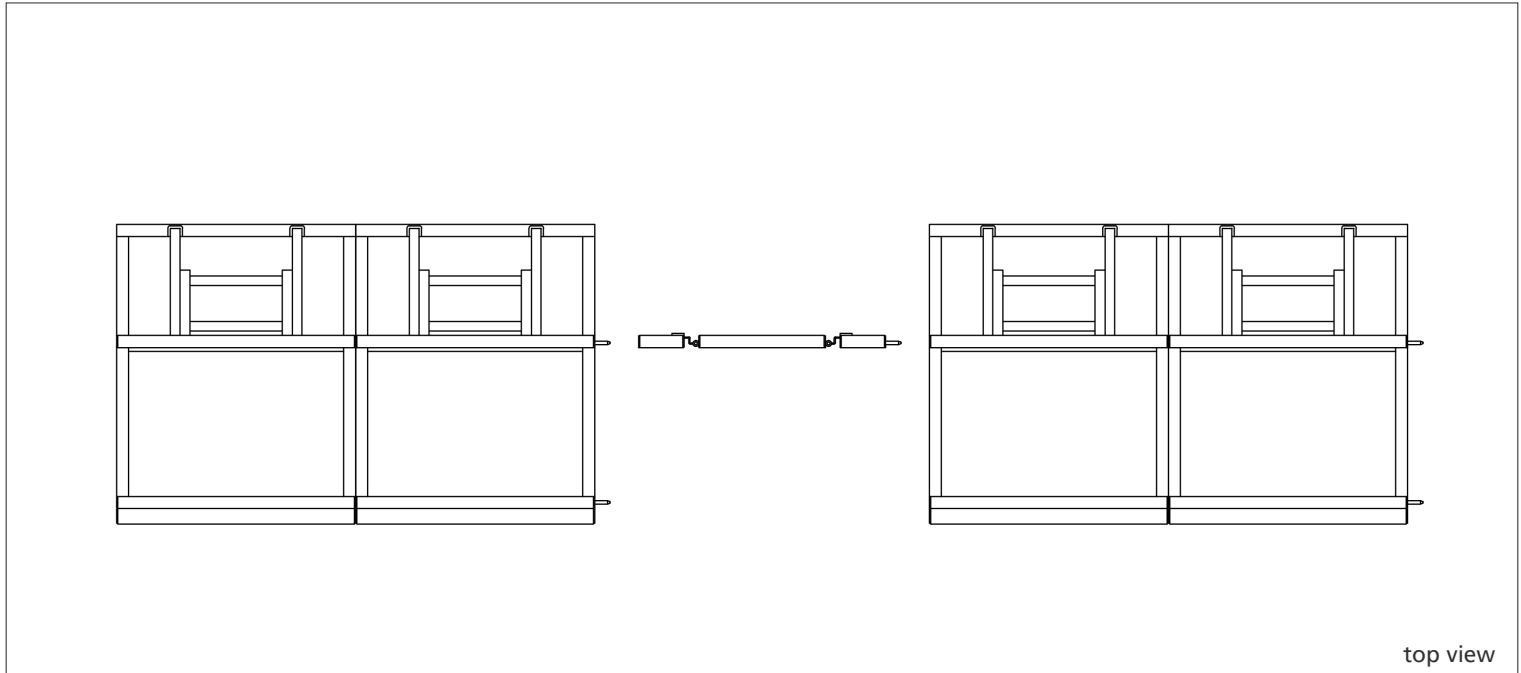

Testing was done at a minimum of 5kN/m pressure at the top rail, following and exceeding the Temporary Demountable Structures Edition 4 guidelines by the Institution of Structural Engineers (ISE). TUV reports for each test are available at Dutch Barrier & Dutch Barrier Services upon request.

- a state of the art aluminium barrier system, built for fast setup and optimised crowd control solutions -

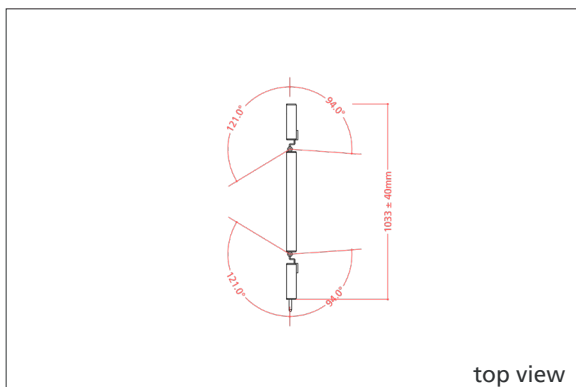
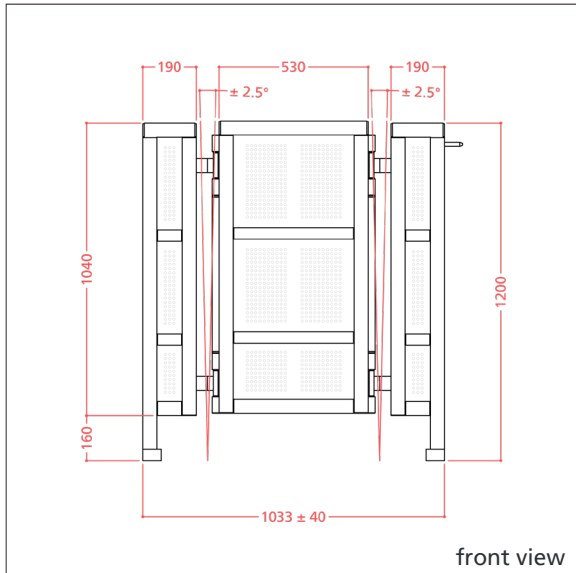

Technical Specs

- A solid welded aluminium mid-construction made of bespoke extrusion profiles that sits between two clever hinges. The hinges provide three degrees of freedom, so most unusual corners, changes in elevation and minor width differences can be negotiated
- One unit measures 1033 ± 40mm wide, 60mm deep and 1200mm high
- Can be used to bridge cables and cableramps
- A rounded top rail and welded end caps for the audience's comfort & and safety
- Top pin provides for easy setup and alignment
- Solid internal and external blocks allow for added strength and easy insertion of pins and bolts
- Flex sections connect to straight sections by two standard Dutch Barrier bolts on either side
- Also available in black
- Weight 21,8kg
- Stored and travel per 15 units in a bespoke stainless steel dolly
- Use in high crowd pressure areas: ●●○○ 3/5

- a safe show for every row -