

## DB Vario Corner Section

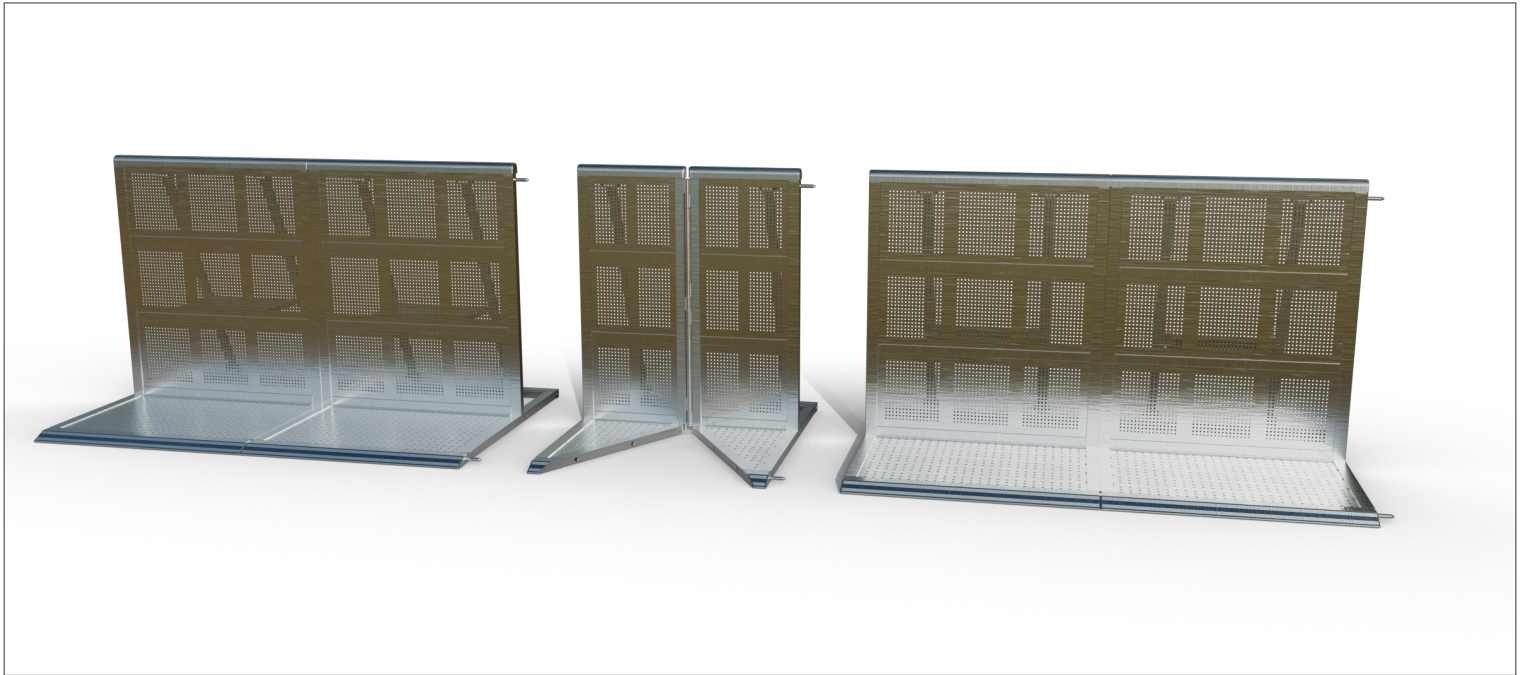

Dutch Barrier's vario corner section is an intelligent corner system. Apart from being a variable corner, applying a standard range of infills in the treadplates makes up for all fixed corners. The infills provide continuity and added strength to the treadplate of the whole setup. It provides a rock-solid crowd control solution in front of stages and other event locations..

**- a state of the art aluminium barrier system, built for fast setup and optimised crowd control solutions -**

### About

Dutch Barrier's founders and partners boast over 50 years of experience in high-end manufacturing, layout design, and crowd control solutions. We saw an opportunity to start afresh with an entirely new stage barrier design, preserving the best features and improving upon them where possible.

### Why

We believe in quality, safety, and creating an unforgettable experience. The safer an audience is, the more comfortable it will feel at your event.

### How

We achieve quality and safety by leveraging 50-plus years of combined original creators' experience to reinvent the to date world's best barrier system from the ground up, making it accessible to anyone who might be in the market for such a system, either to rent or to buy.

### What

Dutch Barrier® is a state-of-the-art lightweight aluminium barrier system offering an innovative combination of straights, special sections and storage solutions. Create ingenious crowd control solutions, enjoy quick setups and enhanced handling, and benefit from an equal footprint for every dolly during transport or storage.

### Oh, and there's one more thing...

Dutch Barrier® is not just a brand. It's a state-of-the-art engineering company where customer support is an integral part of the mission rather than being hidden behind the impersonality of an online promise.

**More information:** [info@dutchbarrier.nl](mailto:info@dutchbarrier.nl)  
**Rental & Sales:** [info@dutchbarrier.services](mailto:info@dutchbarrier.services)

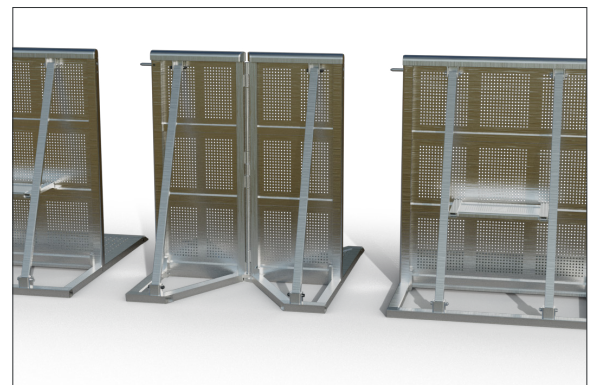
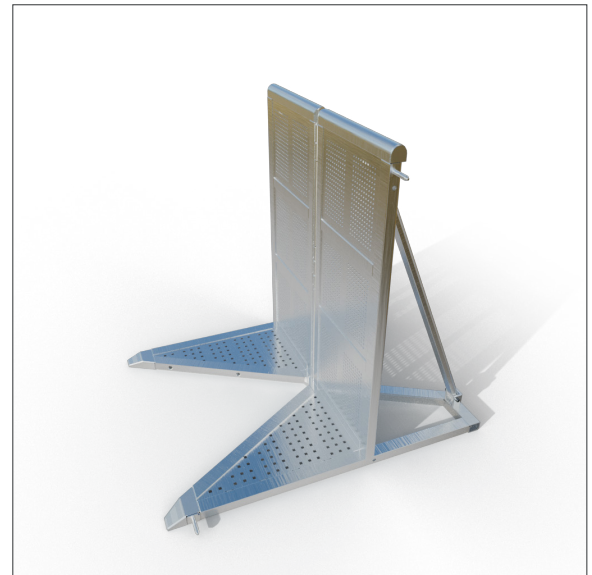

**- a safe show for every row -**

## DB Vario Corner Section

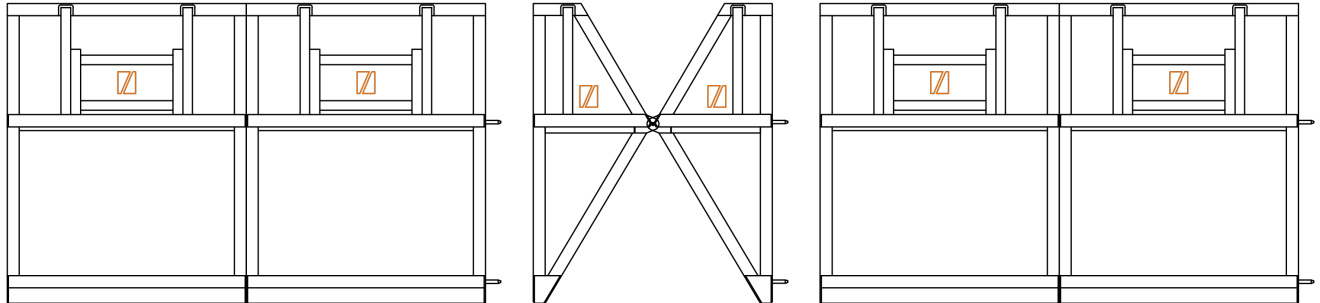

top view

Testing was done at a minimum of 5kN/m pressure at the top rail, following and exceeding the Temporary Demountable Structures Edition 4 guidelines by the Institution of Structural Engineers (ISE). TUV reports for each test are available at Dutch Barrier & Dutch Barrier Services upon request.

**- a state of the art aluminium barrier system, built for fast setup and optimised crowd control solutions -**

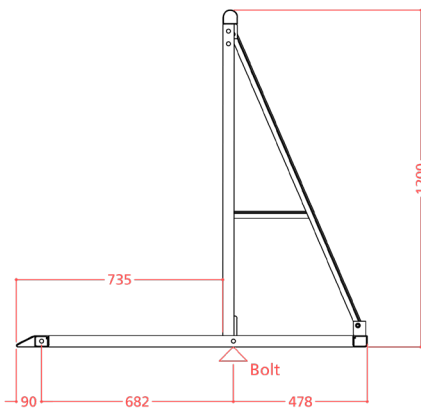

side view

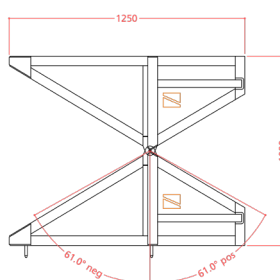

top view

### Technical Specs

- A solid (foldable) A-frame welded aluminium construction made out of bespoke extrusion profiles. The hinge in the centre of the upright provides for positive and negative corners up to 61°
- One unit measures 1000mm wide, 1250mm deep and 1200mm high
- Infill specs are provided on a separate sheet
- A rounded top rail and welded end caps for the audience's comfort & safety
- A punched tread plate prevents liquids from pooling
- Top and bottom pins provide easy setup and alignment
- Clever design enables handling without the risk of trapped fingers
- Internal solid blocks allow for added strength and easy insertion of pins and bolts
- Vario sections interconnect, under normal conditions, at the bottom on either side by one standard Dutch Barrier bolt. In negative corners top bolts are recommended as well
- Also available with black upright and braces
- Weight 35,4kg
- Stored and travel per 10 units in a stainless steel dolly
- Use in high crowd pressure areas: ●●●● 5/5

**- a safe show for every row -**